

Sight Glass Level Gauges
Type 700

OPERATION AND MAINTENANCE MANUAL

Table of contents

	Page
1. FIELD OF APPLICATION	5
1.1 Use as agreed	5
1.2 Hints for guarantee	5
1.3 Disposal	5
2. FUNCTION	6
2.1.1 Tubular glass level gauge	6
2.1.2 Sight glass level gauges with sight glass plates according to DIN 7081	6
2.1.3 Sight glass level gauges with mica window	7
- <i>Refraction type</i>	8
3. CONSTRUCTION OF THE DEVICES	8
3.1 Ball check valves	8
3.2 Gauge body	9
3.2.4 Uninterrupted indication	10
3.2.5 Lever positions	10
4. PUTTING INTO OPERATION	11
4.1 Mechanical assembly	11
4.1.1 Tubular glass level gauge	11
4.1.2 Sight glass level gauges	12
- <i>Assembly of view prolongation</i>	13
- <i>Spare part list view prolongation made of acrylic glass</i>	13
4.2 Putting into operation	14
4.2.1 General hints	14
4.2.2 Tubular glass level gauge	14
- <i>Tubular glass level gauge with hand wheel shut-off gauge valves (type 700.01XX)</i>	14
- <i>Tubular glass level gauge with quick-closing gauge heads (type 700.02XX)</i>	14
4.2.3 Sight glass level gauge	14
- <i>Sight glass level gauge with hand wheel shut-off gauge valves</i>	15
- <i>Sight glass level gauge with quick-closing gauge heads, simple shut-off</i>	15
- <i>Sight glass level gauge with quick-closing gauge heads, double shut-off</i>	15
- <i>Warming up the gauge with the process medium</i>	15
4.3 Electrical connections	16
4.4 After putting into operation	16
4.5 Operating state	16
5. OPERATION	16
6. MAINTENANCE	16
6.1 Gauge body	17
6.1.1 Cleaning	17
- <i>Sight glass level gauge with mica sheets, boiler-level gauge</i>	17
6.1.2 Sealing	17
- <i>Tubular glass level gauge</i>	17
- <i>Sight glass level gauge</i>	17
6.2 Gauge valves	18
6.2.1 Glass tube gauge heads	18
- <i>Cleaning</i>	18
- <i>Sealing</i>	18
6.2.2 Sight glass level gauge gauge heads	18
- <i>Cleaning</i>	18
- <i>Sealing</i>	18
7. REPAIR	18
7.1 Level gauge	18

7.1.1 Tubular glass level gauge	18
7.1.2 Sight glass level gauge	19
- <i>Glass exchange</i>	19
- <i>Spare parts sealings, cushions, FEP foils and mica sheets</i>	20
- <i>Exchanging mica packets</i>	22
- <i>Spare part list mica sheets and sealings</i>	22
- <i>Table mica packets</i>	23
7.2 Gauge heads	23
8. SAFETY NOTES	23
9. BEHAVIOUR IN CASE OF TROUBLE	23

1. FIELD OF APPLICATION

KSR KUEBLER Sight Glass Level Gauges type 700 are for direct optical indication of liquid levels in general applications as well as steam condensate in boilers.

According to the principle of communicating tubes the level is transferred from the vessel to the level gauge. Safe operation is ensured by gauge valves.

These level gauges can be used for all media for which the material used is suitable. Please follow the data written on the name plate. For operation under high vibration load special designs will be used, see specification. Please avoid the use with such media which may lead to strong deposition or crystallisation to ensure proper readability.

Attention: When using with water below the freezing point the level gauge should be heated or at least the water should be drained before to avoid any damage.

1.1 Use as agreed

KSR Kuebler Sight Glass Level Gauges are measuring devices and should be handled with care. The user shall have full knowledge about the relevant local laws, technical rules, accident prevention, installation and operating conditions.

The producer bears full responsibility for the design and execution acc. to the customer's specification.

The customer bears full responsibility for installation and operation as agreed.

The level gauges are designed for static operation without harmful vibrations. Other conditions have to be agreed explicitly. The customer shall take care for the means to reduce vibrations on his own responsibility.

Measures against Internal exothermic reactions as well as against external fire shall be taken by the customer.

When changing the operating conditions the customer shall check the parameters for the suitability of the level gauge.

1.2 Hints for guarantee

All our products are produced and tested according to the general practice of technique and the actual technical rules.

KSR Kuebler AG takes guarantee for products and spares in accordance with the conditions agreed by exchange of faulty parts. Glasses, mica sheets and sealings/gaskets are wear parts which are excluded from any guarantee claims, because the operating conditions and the materials properties may effect the life time unforeseen. Valve trim parts are also excluded from warranty as soon as these have been damaged by particles.

We reference additionally to the maintenance and installation manual which is mandatory.

Before putting into operation the customer shall check for the suitability of the design parameters of the level gauge and the operating conditions.

1.3 Disposal

The customer/enduser is obliged to take care for the disposal within the legal regulations.

2. FUNCTION

2.1.1 Tubular glass level gauge

The liquid level is visible from all directions through a pressure-tight glass-tube made of Borosilicate-glass.

2.1.2 Sight glass level gauges with sight glass plates according to DIN 7081

- Reflex type

Incident light is reflected at the reflex grooves of the sight glass plate covered by gas and is broken into the liquid in the part covered by medium. The liquid level is visible as a dark bar, the gaseous space as a silvery bar.

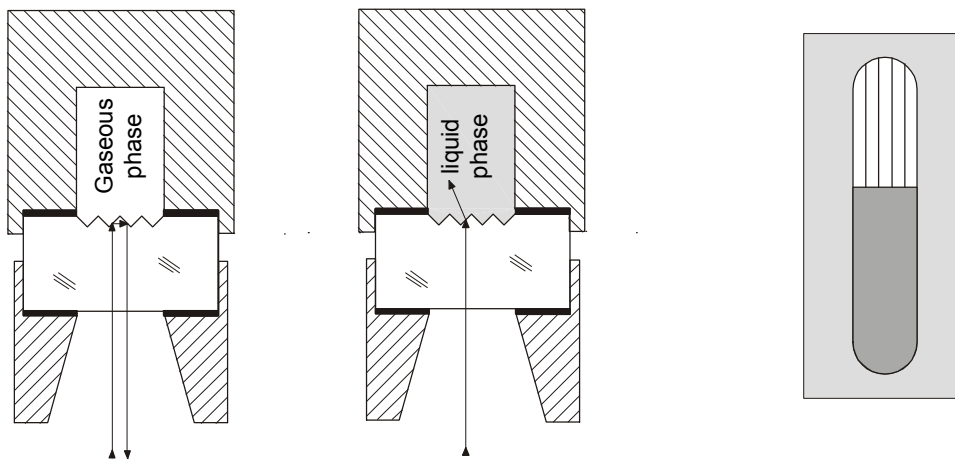

Schematic diagram: Trace of the rays in gaseous and liquid phase

- **Transparent type**

Incident light (daylight or the light of a lamp) passes both sight glass plates, between whose the medium is located. The filling level is visible as a dash (meniscus) or by the liquid itself.

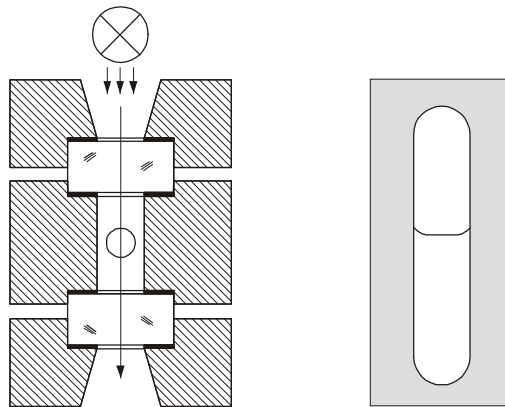

Schematic diagram: Trace of the rays

2.1.3 Sight glass level gauges with mica window

- **Transparent type**

Function is like described in 2.1.2. For these indicators an illumination is always necessary to get a clear reading of the filling level.

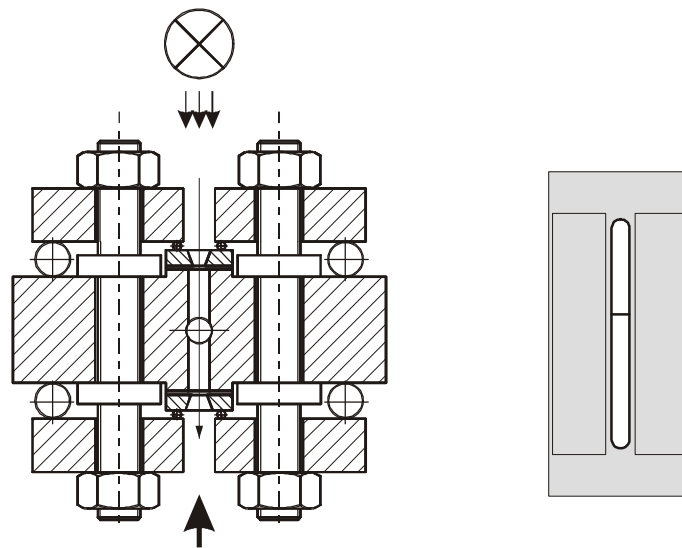

Schematic diagram: Trace of the rays

- **Refraction type**

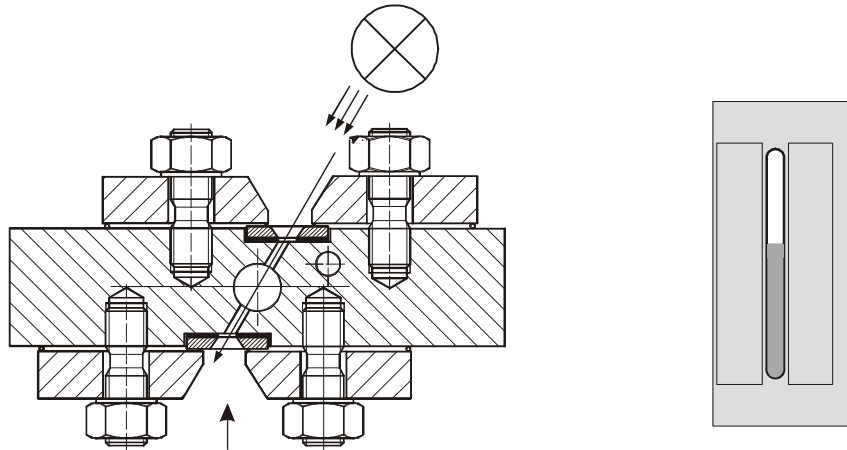

The incident light of a lamp is guided through the two mica sheet packages in an angle and passes the medium between them. In gaseous phase the light is guided straight forward and passes both mica packets, in liquid the light is refracted away. The liquid level is visible as a black bar and the gas as a bright bar.

3. CONSTRUCTION OF THE DEVICES

Basically all sight glass level gauges consist of the gauge body and gauge heads with safety ball check.

All representations are symbolic and can differ acc. to order specifications. Drain or vent are available as plugs, valves, flange studs etc. in various types, connections may be flanges, weld ends,... Special materials and linings may cause geometrical variations. Bridgings and number as well as size of the segments are affected by measuring length and requirements of the specification. As protection of the glasses FEP foils or mica sheets may be used inside or outside.

3.1 Ball check valves

The ball check is a safety facility used in all gauge heads. It prevents the flow out of the medium when glass or mica breakings occur while gauge heads are fully open.

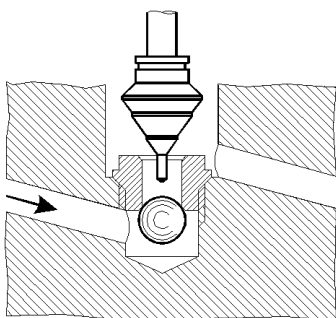

Ball check in action

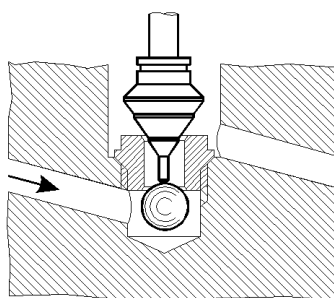

Ball check at putting into service

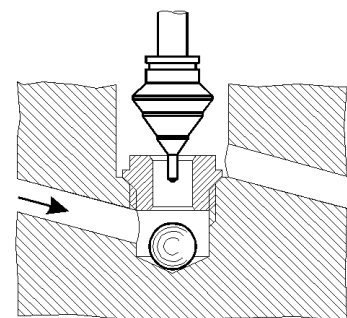

Ball check in operation

There is a ball under the valve seat. As soon as the indicator gets leaky, the starting flow raises the ball from its hollow and pushes it against the valve seat ($\Delta p > 0,5 \text{ bar}$). Through this an unrestrained flow out of the medium is stopped as long as the pressure caused by the medium tightly presses the ball against the valve seat. The gauge heads can be closed then. After this the required exchange of glass tubes, glasses or mica sheets can be done.

Attention: During the closing operation the ball is pushed away from the seat short-timely and opens the seat cross-section for a moment. At this moment a small amount of the medium still can flow out! Because of this use protective clothing/spectacles if necessary!

3.2 Gauge body

The sight glass level gauges can be provided additionally with the following equipments:

- Acrylic glass wedge or glass as view prolongation and frost protection at fully isolated indicators
- Scale with graduation (% , cm, ...)
- Pointer for MIN or Max indication
- Measuring facilities for the remote control of level limits
- Illumination, also available in Ex

3.2.4 Uninterrupted indication

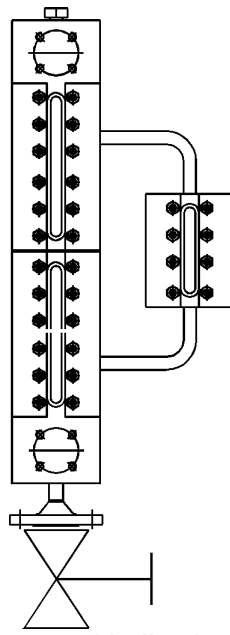

Example of an uninterrupted indication at the type 700.251X

3.2.5 Lever positions

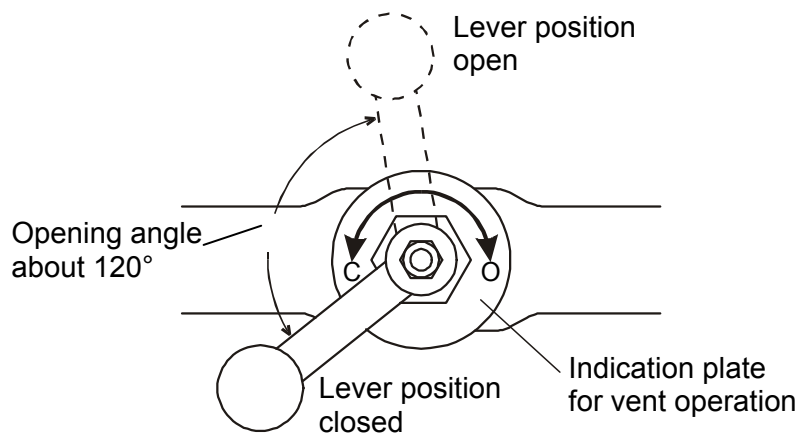

Type closing counterclockwise

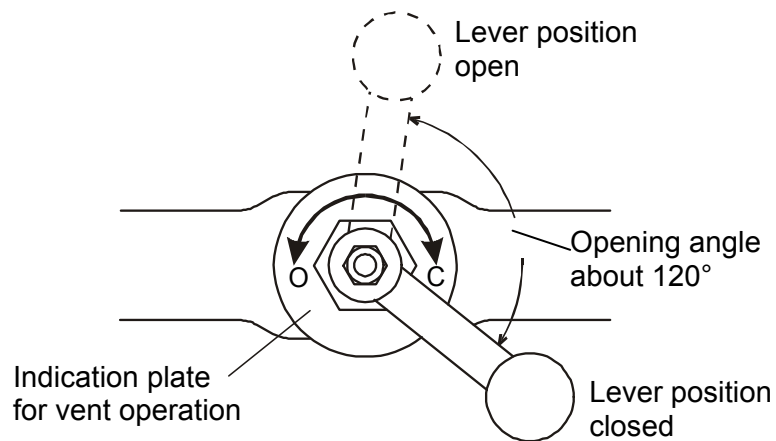

Type closing clockwise

4. PUTTING INTO OPERATION

The sight glass level gauges are manufactured in accordance with the publicly valid regulations and the specifications of the customer. You should check the conformance of the specifications with the requirements of the plant.

Before the assembly

- The devices have to be checked for perfect condition
- The mounting position (top, bottom) must be compared with the device type
- The center to center distance and connection type at the vessel have to be compared with the measures of the delivered device. Maximum deviation: +/- 1 mm.
- At the mounting it has to be ensured that the gauge is assembled free of canting or distortion.
- The seal plugs or covers of the openings of the gauge heads have to be removed before assembly.
- Corresponding work and measurement gears are to be provided; special tools aren't necessary

Attention: By suitable, site oriented measures it has to be guaranteed that shocks and/or vibrations (for outer plants take wind into account) aren't imparted to the device.

4.1 Mechanical assembly

4.1.1 Tubular glass level gauge

At the assembly of tubular glass level gauges some additional specialties have to be taken into account, e. g. whether sufficient free space up to the ceiling is available for inserting the glass tubes or not.

Depending on accessibility the following assembly sequences is suggested:

Glass tube assembly from above at sufficient ceiling free space

- Remove covers from the connection flanges
- Assemble gauge heads to the vessel connections; take care of axial alignment
- Remove upper seal screw
- Pull the glass tube from above through the gauge head and packing parts and set it on the neck ring of the lower gauge head
- Put the packings into the upper and lower seat and tighten the sleeve nuts with approx. 5 Nm (with firm hand + 1/2 turn)
- Tighten the upper seal screw with a new seal and fasten it with 80-100 Nm

Glass tube assembly between the gauge heads at inadequate ceiling free space

- Remove covers from the connection flanges
- Assemble gauge heads to the vessel connections; take care of axial alignment
- Remove the upper sleeve nuts, stuffing boxes and packing rings (as well as upper gasket) off the gauge heads and shove them over the tube ends
- Insert the glass tube into the upper gauge head only, then move it into the lower gauge head down to the gasket
- Put packings into the upper and lower seat and tighten the sleeve nuts with approx. 5 Nm (with firm hand + 1/2 turn)

At indicators with glass holders proceed analogously.

Protection devices

Protection devices are delivered depending on indicator length in undivided or divided type.

- Undivided protection tubes are inserted together with the glass tubes
- Divided protection tubes are fastened after the glass tube assembly with clamping springs
- Other protection devices e.g. those of wire or Plexiglas have to be fastened according to the prepared clamp devices

After the assembly all accompanying shut-off devices have to be closed. (See 3.2.5 lever positions)

4.1.2 Sight glass level gauges

- Remove covers from the connection flanges
- Assemble the completely assembled delivered indicators stressfree to the vessel connections
- For lifting use textile tapes to avoid damages
- At pivotable types the corresponding threaded joints must be opened approx. 2 turns and be fastened after the positioning of the indicator with approx. 25 Nm.
- The nuts of the glass or mica covers have to be fastened in accordance to the picture with a torque wrench (particularly also before the first putting into service):

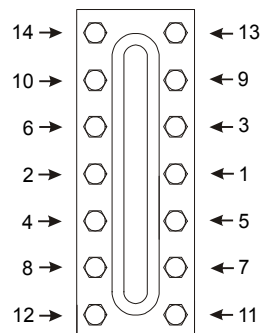

Screw	Norm	Size	Force [Nm]	Pressure Class
BOLT SCREW	DIN 938/939	M10	35	40 / CLASS 300
BOLT SCREW	DIN 938/939	M12	45	40 / CLASS 300
ELONGATION SCREW WITH 3 BELLEVILLE SPRINGS 25X12X1.5	DIN 976 DIN 2093	M12	90	64
ELONGATION SCREW WITH 3 BELLEVILLE SPRINGS 31X16X2	DIN 976 DIN 2093	M16	150	100 / CLASS 600
ELONGATION SCREW WITH 3 BELLEVILLE SPRINGS 40X20X2.5	DIN 976 DIN 2093	M20	180	160 / CLASS 900 250 / CLASS 1500
FOR TYPE 700.25XX: ELONGATION SCREW WITH 3 BELLEVILLE SPRINGS 40X20X2.5	DIN 976 DIN 2093	M20	100-110	250 / CLASS 1500
ELONGATION SCREW WITHOUT SPRINGS	DIN 976	M20	100-110	250 / CLASS 1500

Pay attention that after mounting all accompanying stopping devices are closed (see 3.2.5 lever positions).

- **Assembly of view prolongation**

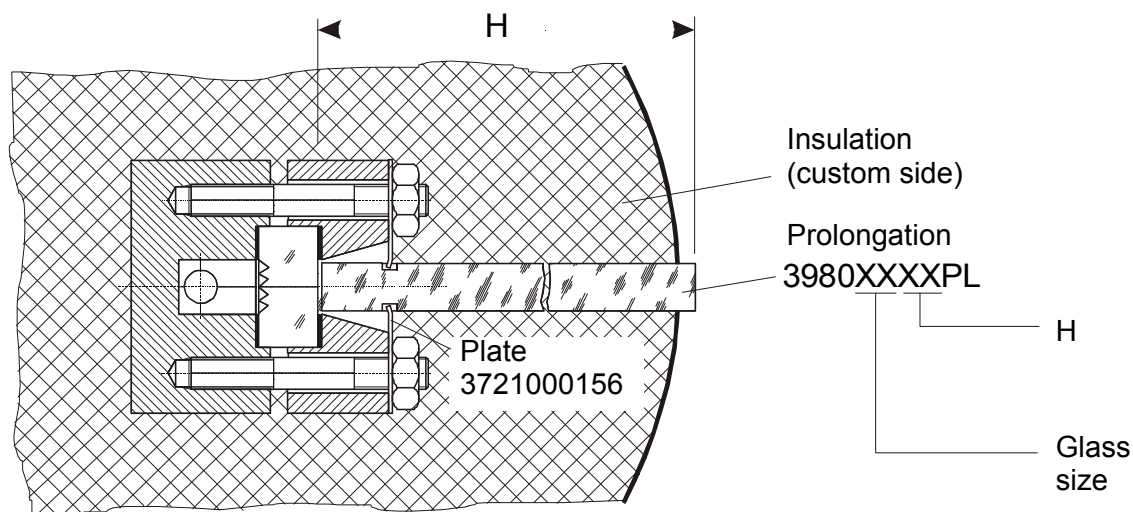

- **Spare part list view prolongation made of acrylic glass**

Glass -size	Length L	Height H									
		02	03	04	05	06	07	08	09	10	11
		Hight H in mm at temperature									
		0 ... 20 °C	21 ... 40 °C	41 ... 60 °C	61 ... 80 °C	81 ... 100 °C	101 ... 120 °C	121 ... 140 °C	141 ... 160 °C	161... 180 °C	181... 200 °C
0	72	40	60	80	100	120	140	160	180	200	220
1	92	40	60	80	100	120	140	160	180	200	220
2	117	40	60	80	100	120	140	160	180	200	220
3	142	40	60	80	100	120	140	160	180	200	220
4	167	40	60	80	100	120	140	160	180	200	220
5	197	40	60	80	100	120	140	160	180	200	220
6	227	40	60	80	100	120	140	160	180	200	220
7	257	40	60	80	100	120	140	160	180	200	220
8	297	40	60	80	100	120	140	160	180	200	220
9	317	40	60	80	100	120	140	160	180	200	220
10	347	40	60	80	100	120	140	160	180	200	220
11	377	40	60	80	100	120	140	160	180	200	220
12	407	40	60	80	100	120	140	160	180	200	220
13	437	40	60	80	100	120	140	160	180	200	220
14	477	40	60	80	100	120	140	160	180	200	220
15	507	40	60	80	100	120	140	160	180	200	220
16	537	40	60	80	100	120	140	160	180	200	220
17	577	40	60	80	100	120	140	160	180	200	220
18	607	40	60	80	100	120	140	160	180	200	220
19	637	40	60	80	100	120	140	160	180	200	220
20	677	40	60	80	100	120	140	160	180	200	220

4.2 Putting into operation

4.2.1 General hints

The sight glass level gauges for liquids are normally delivered with gauge heads with simple shut-off or quick-closing (lever).

Boiler-level gauges for steam-boilers are usually delivered with double closing gauge heads (a quick-closing valve with lever actuation and a shut-off valve with hand wheel).

The sight glass level gauges are generally delivered (see 3.1) with ball check. At putting into operation open the gauge head's valves only as far as approx. 20°, so that the tip of the valve cone keeps the ball away from the valve seat to enable the medium flow into the gauge body (Glass or mica holder). If the pressure balance with the vessel is accomplished, the valves can be opened completely.

Attention: To avoid stress – especially with hot media - the level gauge must be warmed up slowly (see 4.2.3.4). This action is not necessary if the medium has nearly environmental temperature.

4.2.2 Tubular glass level gauge

- *Tubular glass level gauge with hand wheel shut-off gauge valves (type 700.01XX)*

- Slowly open the **upper** gauge valve with ½ - 1 turn to avoid that the ball check comes into action
- After pressure balance open completely
- Only then open the **lower** gauge valve slowly till level compensation has been reached
- After this open completely
- Check for tightness of all connections

- *Tubular glass level gauge with quick-closing gauge heads (type 700.02XX)*

- Open levers of the **upper** gauge head slowly for approx. 20°, direction of rotation see 3.2.5
- After pressure balance open completely (lever up)
- Only then open the **lower** gauge head slowly for approx. 20° till level compensation hasw been reached
- After this open the lever completely
- Check for tightness of all connections

4.2.3 Sight glass level gauge

Attention: When opening the drain valve: With dangerous media the drain valve may be opened only for a short time so that condensate forming can drain away. At this point **most caution** is advisable. Wear protective clothing/spectacles if necessary.

- **Sight glass level gauge with hand wheel shut-off gauge valves**
 - Slowly open the **upper** gauge valve for $\frac{1}{2}$ - 1 turn to avoid that the ball check comes into action
 - After pressure balance open completely
 - Only then slowly open the **lower** gauge valve until level compensation has been reached
 - After this open completely
 - Check for tightness of all connections
 - Tightening of the lid nuts is necessary, repeatedly in the first time after putting into operation, then 2-3 times within 24 h, until the torque remains constant

- **Sight glass level gauge with quick-closing gauge heads, simple shut-off**
 - Slowly open levers of the **upper** head for approx. 20° to avoid that the ball check comes into action, direction of rotation see 3.2.5
 - Open after pressure balance on approx. 120° (lever up)
 - Only then slowly open the **lower** head for approx. 20° until level compensation has been reached
 - After then open the lever for approx. 120°
 - Check for tightness of all connections
 - Tightening of the lid nuts is necessary, repeatedly in the first time after putting into operation, then 2-3 times within 24 h, until the torque remains constant (4.1.2)

- **Sight glass level gauge with quick-closing gauge heads, double shut-off**
 - Check that **both** valves of the gauge heads are closed
 - Open **upper** quick-closing lever completely, direction of rotation see 2.2.1
 - Slowly open the hand wheel of the **upper** head $\frac{1}{2}$ - 1 turn to avoid that the ball check comes into action
 - After pressure balance open completely
 - Open **lower** quick-closing lever completely, direction of rotation see 2.2.1
 - Slowly open the hand wheel of the lower head $\frac{1}{2}$ - 1 turn
 - After level compensation open completely
 - Check for tightness of all connections
 - Tightening of the lid nuts is necessary, repeatedly in the first time after putting into operation, then 2-3 times within 24 h, until the torque remains constant (Section 4.1.2)

- **Warming up the gauge with the process medium**
 - Take into account pollution control regulations
 - Attach condensate drain hose to the outlet of the drain valve and ensure safe drain
 - Slowly open drain valve to avoid that the ball check comes into action
 - Slowly open upper gauge head to avoid that the ball check comes into action
 - Open the hand wheel valve $\frac{1}{2}$ - 1 turns
 - Open quick-closing valve approx. 20°
 - Continue the warm-up process till the indicator nearly has operating temperature
 - As soon as a clearly recognizable liquid level occurs, open all gauge valves fully so that the ball check can get effective at decompression in the indicator e.g. at glass or mica breaking.
 - After then open the upper gauge head, then close the drain valve again and start the filling process in accordance with 4.2.2 or 4.2.3. Level gauges with heat tracing can be warmed up using this.

4.3 Electrical connections

- The installation of electrical lines to illumination devices or measuring facilities has exclusively to be carried out by experts with professional education. The safety rules for work on electrical devices have to be taken into account.

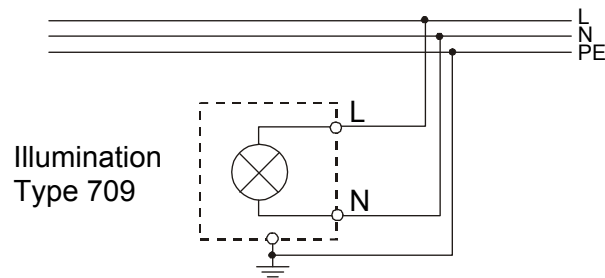

Electrical connection of illumination

4.4 After putting into operation

The lid screws/nuts of the level gauges still have to be tightened several times since sealings and cushions of the glasses or the mica sheets are settling with time, see 4.1.2.

4.5 Operating state

The gauge heads are fully open during the operation. In case of dangerous they have to be closed by a turn of the quick-closing levers for approx. 90°. At steam-boilers the second blocking device is then closed with the hand wheel.

The handles of the quick-closing device can be delivered on request with eyes to provide simultaneous operation of the gauge heads with chains or linkages.

5. OPERATION

- For a clear recognition of the liquid level no disturbing influences such as too strong light on the observer side, mirroring, reflection, too strong darkening or dirty inside surfaces should be avoided.
- The illumination devices must shine into the window directly.
- The valve lever position must be comply with the details to 3.2.5.
- To protect against injuries protective measures shall always be met:
 - Wear safety goggles
 - Use gloves, when possible wear protective clothing

6. MAINTENANCE

Sight glass level gauges should be maintained in regular intervals. Control the glass tubes, glass plates or mica sheets for their condition, since some liquids, e.g. fully desalted water, may attack glass to a great extent.

For mica take into account that it is subject to a certain wear as it is a natural product. At application of the required care, however, this can be reduced to a tolerable measure.

Maintenance work - besides cleaning of the glass tubes, gauge body and gauge valves - includes tightening of bolted joints and re-pressing of stuffing box packings.

6.1 Gauge body

6.1.1 Cleaning

- Close gauge heads
- Open vent plug slowly until pressure balance with the environment has been reached
- Unscrew vent plug
- Take measures to collect or let off the medium
- Open drain plug or open drain valve and drain away medium
- Fill in medium or other permissible liquid provided that this is wholesome with the medium and the glasses or mica slices from above and clean the gauge inside, if necessary with a brush.
- Screw in plugs with new sealings and tighten with 80 - 100 Nm/ close drain valve
- Put gauges into operation according to section 4.2

- ***Sight glass level gauge with mica sheets, boiler-level gauge***

- Close the hand wheel shut-off valves.
- The quick-closing valves (with lever actuation) remain open.
- Open the drain valve.
- Slowly open the hand wheel of the upper gauge head so that the steam can drain without triggering the ball check.
- Blow through the indicator with steam.
- After blowing through the gauge heads are closed as described under 2.2.

The glasses or mica sheets can in addition be washed from below. To do this, proceed as follows:

- After blowing through close the drain valve first.
- Then close the hand wheel of the upper gauge head.
- Open the vent plug.
- Open the hand wheel of the lower gauge head slowly so that the ball check doesn't get effective. The water is pressed into the gauge body (glass-/ mica holder) now and removes the dirt.

Attention: Gauges with mica equipment only then should be blown through at putting into operation or cleaning, if there are considerable coverings inside to avoid a flaking of the mica.

Under no circumstances clean mechanically!

6.1.2 Sealing

- ***Tubular glass level gauge***

- Fasten sleeve nuts carefully to the glass tube sealing packings in accordance with section 4.1.2

- ***Sight glass level gauge***

- At seated sealings the nuts of the glass- or mica holders are to be tightened in accordance with section 4.1.2

6.2 Gauge valves

6.2.1 Glass tube gauge heads

- **Cleaning**

Glass tube gauge heads have a horizontal cleaning opening. These gauge heads shall be cleaned only if the vessel is depressurised and the level is below 0.

- Open gauge valves completely
- Unscrew cleaning plugs and clean this opening
- Screw in plug with new sealing and tighten with approx. 40 Nm.

- **Sealing**

- Tighten sleeve nut of the packing carefully

6.2.2 Sight glass level gauge heads

- **Cleaning**

Sight glass level gauge heads don't have any cleaning opening.

Cleaning can be therefore carried out only in the fully removed state.

This is generally carried out in the context of repair work. (Section 7)

- **Sealing**

- Tighten sleeve nut of the packing carefully

7. REPAIR

Attention:	Glass and mica exchange only should be carried out by trained staff because careful and clean work is required for this!
-------------------	--

For security reasons we recommend to use only original spare parts from **KSR Kuebler AG**.

7.1 Level gauge

7.1.1 Tubular glass level gauge

Exchange damaged glass tubes as follows:

- Depressurise vessels.
- Close the lower gauge head.
- Close the upper gauge head.
- Open the drain valve to drain the residual liquid off the gauge (take into account pollution regulations).
- Remove protection devices.
- Remove the damaged glass tube and the sealings.
- Insert new elastomer sealings.
- Inserting the glass tube and assembly of the protection devices are carried out as described under 4.1.1.
- Carry out tightness test.
- The putting into operation is carried out in accordance with the 4.2.1.

7.1.2 Sight glass level gauge

- Glass exchange

Attention: At every glass exchange it has to be respected that you don't damage the sealing surface! Furthermore it has to be checked before the assembly whether the correct glass size and the required glass quality is used (Preferably borosilicate quality in accordance with DIN 7081).

- Depressurise vessels.
- Let medium drain away (take into account pollution regulations)
- Unscrew the lid nuts.
- Lift the lid.
- Remove faulty glasses and loose sealing parts.
- Clean sealing area (do not use sharp-edged tools!).
- Insert the new sealing into the sealing area.
- Insert the cushion with the glass into the lid.
- Insert reflection glasses with the grooves in direction to the liquid channel.
- The glasses must have clearance in the lid to all sides.
- Put on the lid over the bolts again.
- Tighten the nuts as described under 4.1.2.
- Carry out tightness check.
- Tighten the nuts in intervals of 24 hours with torque screw wrench, as described under 4-1-2.

Provided that the sight glass level gauges are equipped with mica protection or corrosion protection devices (FEP), those are put in front of or behind the glass corresponding with the above mentioned instructions.

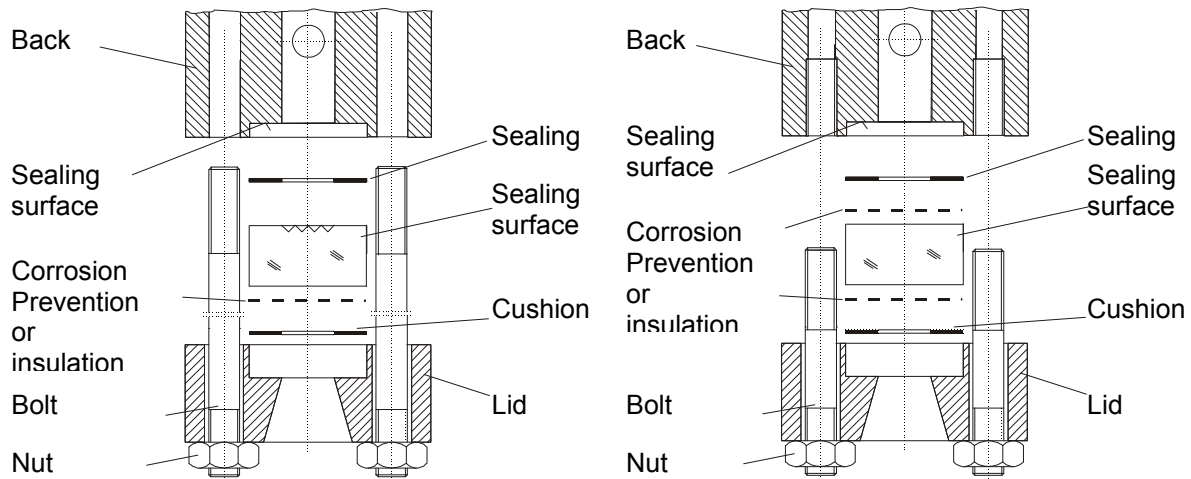

- Spare parts sight glass plates according to DIN 7081

Glass plates DIN 7081					
Length	No.	Order no. Reflex glass B x H 34 x 17	Order no. transparent glass B x H 34 x 17	Order no. Reflex glass B x H 34 x 21	Order no. transparent glass B x H 34 x 21
95	0	D07081G095R	D07081G095T	DS7081G095R	DS7081G095T
115	1	D07081G115R	D07081G115T	DS7081G115R	DS7081G115T
140	2	D07081G140R	D07081G140T	DS7081G140R	DS7081G140T
165	3	D07081G165R	D07081G165T	DS7081G165R	DS7081G165T
190	4	D07081G190R	D07081G190T	DS7081G190R	DS7081G190T
220	5	D07081G220R	D07081G220T	DS7081G220R	DS7081G220T
250	6	D07081G250R	D07081G250T	DS7081G250R	DS7081G250T
280	7	D07081G280R	D07081G280T	DS7081G280R	DS7081G280T
320	8	D07081G320R	D07081G320T	DS7081G320R	DS7081G320T
340	9	D07081G340R	D07081G340T	DS7081G340R	DS7081G340T
370	10	D07081G370R	D07081G370T	DS7081G370R	DS7081G370T
400	11	D07081G400R	D07081G400T	DS7081G400R	DS7081G400T
430	12	D07081G430R	D07081G430T	DS7081G430R	DS7081G430T
460	13	D07081G460R	D07081G460T	DS7081G460R	DS7081G460T
500	14	D07081G500R	D07081G500T	DS7081G500R	
530	15	D07081G530R	D07081G530T	DS7081G530R	
560	16	D07081G560R	D07081G560T		
600	17	D07081G600R	D07081G600T		
630	18	D07081G630R	D07081G630T		
660	19	D07081G660R	D07081G660T		
700	20	D07081G700R	D07081G700T		

- **Spare parts sealings, cushions, FEP foils**

- **and mica sheets**

Length	No.	Order no. Sealing	Order no. Cushion	Order no. FEP foils	Corrosion prevention up to 200 °C	Corrosion prevention to 300 °C and as heat insulation between medium and environmental temperature	Corrosion prevention to 300 °C and as heat insulation between medium and environmental temperature
					Order no. Mica sheets B = 34 mm 0.2...0.3 mm	Order no. Mica sheets B = 34 mm 0.3 mm 1. Quality, clear	
95	0	35290030XXX	35290000NEFA	39903000FEP		39890800GL	39891800GL1Q
115	1	35290031XXX	35290001NEFA	39903001FEP		39890801GL	39891801GL1Q
140	2	35290032XXX	35290002NEFA	39903002FEP		39890802GL	39891802GL1Q
165	3	35290033XXX	35290003NEFA	39903003FEP		39890803GL	39891803GL1Q

Length	No.	Order no. Sealing	Order no. Cushion	Order no. FEP foils	Order no. Mica sheets B = 34 mm 0.2...0.3 mm	Order no. Mica sheets B = 34 mm 0.3 mm 1. Quality, clear
190	4	35290034XXX	35290004NEFA	39903004FEP	39890804GL	39891804GL1Q
220	5	35290035XXX	35290005NEFA	39903005FEP	39890805GL	39891805GL1Q
250	6	35290036XXX	35290006NEFA	39903006FEP	39890806GL	39891806GL1Q
280	7	35290037XXX	35290007NEFA	39903007FEP	39890807GL	39891807GL1Q
320	8	35290038XXX	35290008NEFA	39903008FEP	39890808GL	39891808GL1Q
340	9	35290039XXX	35290009NEFA	39903009FEP	39890809GL	39891809GL1Q
370	10	35290040XXX	35290010NEFA	39903010FEP	39890810GL	39891810GL1Q
400	11	35290041XXX	35290011NEFA	39903011FEP	39890811GL	39891811GL1Q
430	12	35290042XXX	35290012NEFA	39903012FEP	39890812GL	39891812GL1Q
460	13	35290043XXX	35290013NEFA	39903013FEP	39890813GL	39891813GL1Q
500	14	35290044XXX	35290014NEFA	39903014FEP	39890814GL	39891814GL1Q
530	15	35290045XXX	35290015NEFA	39903015FEP	39890815GL	39891815GL1Q
560	16	35290046XXX	35290016NEFA	39903016FEP	39890816GL	39891816GL1Q
600	17	35290047XXX	35290017NEFA	39903017FEP	39890817GL	39891817GL1Q
630	18	35290048XXX	35290018NEFA	39903018FEP	39890818GL	39891818GL1Q
660	19	35290049XXX	35290019NEFA	39903019FEP	39890819GL	39891819GL1Q
700	20	35290050XXX	35290020NEFA	39903020FEP	39890820GL	39891820GL1Q

Encoding sealing material

XXX = VG Graphite/Kevlar
 GR Pure graphite
 VI Viton
 STA Statotherm
 PTFE PTFE
 PT0F PTFE, 25% filled with glass fibres
 SIL SIL C

- **Exchanging mica packets**

The drawing represents a boiler-level gauge with mica equipment.

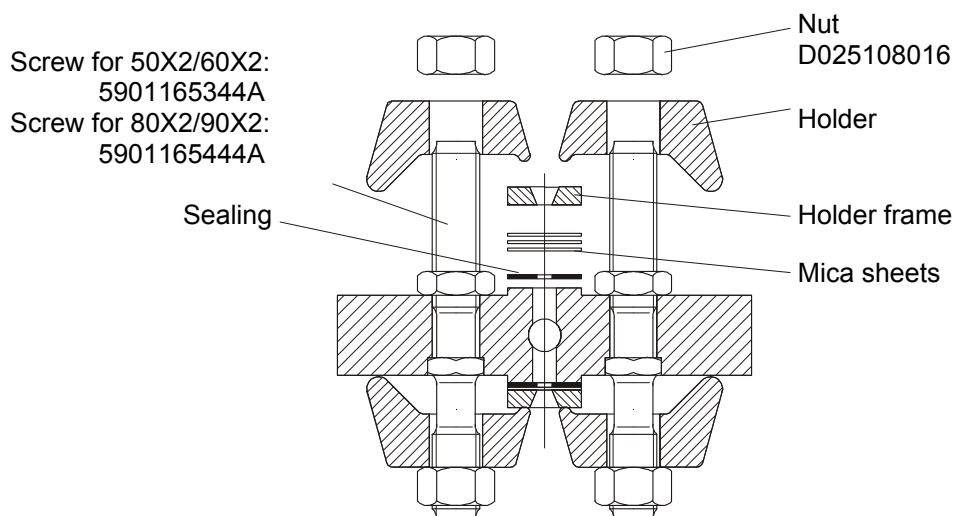

- **Spare part list mica sheets and sealings**

Size similar DIN 7081	Length	Mica sheets B = 25, square		Sealings from Novaphite SGBC 0.5 mm thick
		Order no. Normal quality, 0.2 ... 0.3 mm thick	Order no. 1st quality, clearly transparent, 0.3 mm thick	
4	190	39891709GL	39892709GL	35290230NOV
5	220	39891710GL	39892710GL	35290231NOV
6	250	39891712GL	39892712GL	35290232NOV
7	280	39891713GL	39892713GL	35290233NOV
8	320	39891714GL	39892714GL	35290234NOV
9	340	39891715GL	39892715GL1Q	35290235NOV
Außerhalb der Reihe	420	39891719GL	39892719GL	35290239NOV

Attention: When replacing the mica it has to be respected that the sheets show no splinters or rent injuries on the steam/water side!

Replacing the mica packets is carried out as follows:

- Depressurise the vessel.
- Let medium drain away (notice pollution regulations)
- Unscrew the nuts.
- Remove the holder off the screws.
- Remove the holder frame, the old mica slices and the old sealings.
- The sealing surfaces of the mica holder and holder frame have to be cleaned carefully. Avoid damage of sealing surfaces!
- If the sealing surfaces are damaged, these must be grinded. In this case it is useful to send the parts to **KSR Kuebler AG** for repair.
- Insert a new, rectangle-shaped seal.
- When inserting the mica sheets it has to be respected that the sheets are pointing to the side of the liquid channel with the marking "water side".
- After this the holder is positioned over the mica sheets.
- The holder is now shoved and centred over the screws.

KSR KUEBLER Niveau-Messtechnik AG Heinrich-Kübler-Platz 169439 Zwingenberg am Neckar

- Tighten the nuts, like described under 4.2.2.
- Carry out tightness check.
- After 24 hours tighten the screws repeatedly with torque screw wrench (180 Nm), as described under 4.2.2.

- **Table mica packets**

Operating pressure	Up to 80 bar		Up to 140 bar		above 140 bar	
Number of sheets	3	4	4	6	5	7
Thickness in mm	0.3	0.2	0.3	0.2	0.3	0.2
Packet thickness in mm	0.9	0.8	1.2	1.2	1.5	1.4

7.2 Gauge heads

Gauge heads may be equipped with flange connections, welding ends or thread.

- **It is recommended that repair of valves is done by the supplier.**
- **Repair work done by the plant operator himself shall be carried out only by trained specialist staff which has provably experience with such work. The functional safety of the shut-off devices must be ensured by plant operator authorities after the work. As support for the repair detail drawings and parts lists can be requested.**

8. SAFETY NOTES

- The plant operator must have complete knowledge about the function of the sight glass level gauges. Otherwise he has to obtain special information from the manufacturer
- To prevent injuries protective measures shall always be taken like:
 - Carry safety goggles
 - Wear gloves
 - Wear protective clothing, breath protection at dangerous media
- For the general safety in the case of breakdowns as well as at maintenance works we recommend, to add a shut-off device between vessel and gauge head.
- To ensure early diagnosis of damages the level gauges have to be checked visually in regular intervals for leaks, glass and mica attacks
- The maintenance intervals must be adapted to the operating conditions
- It is urgently required that all work is carried out by trained staff for security reasons

9. BEHAVIOUR IN CASE OF TROUBLE

Attention: In case of a leakage during the operation (leaky packings, broken glass, faulty sealings) the level gauge has to be shut off from the vessel immediately. This is done first with the quick-closing lever, followed by, if given, with the hand wheel of the main shut-off (closing directions of rotation in accordance with 3.2.5)



KSR KUEBLER Niveau-Messtechnik AG

Heinrich-Kübler-Platz 1

69439 Zwingenberg am Neckar

Telefon: 0 62 63/87-0

Telefax: 0 62 63/87-99

E-Mail: info@ksr-kuebler.com

Internet: www.ksr-kuebler.com