

# Glass Tube Liquid Level Gauge PN 10 Type 700.A2

## Applications

Direct reading liquid level indicator with glass tube for general applications up to CL150. Increased safety with ball check valves and glass protection.

## Special Features

- Connection top-bottom pivoted
- Handwheel
- Glass protection

## General Data

Center-to-center ME	max. 1200 mm
Sight length	ME – 70 mm
Diameter of glass tube*)	Ø 13,5 x 1,75mm
Actuation	handwheel
Valve passage	8 mm
Process connection	male thread G 1/2 DIN ISO 228 flange DN 15 - 25 / PN 10

### Materials

- gauge heads brass 2.0401
  - gaskets for glass tube rubber (Perbunan)
  - glass tube DURAN
- The materials may vary depending upon availability.

## Design Data

Design temperature / Design pressure up to 120°C / 10bar

## Accessories

glass protection**)	plexiglass cover Ø 42mm
visual help	coloured float
Scale	division and unity to customers spec.

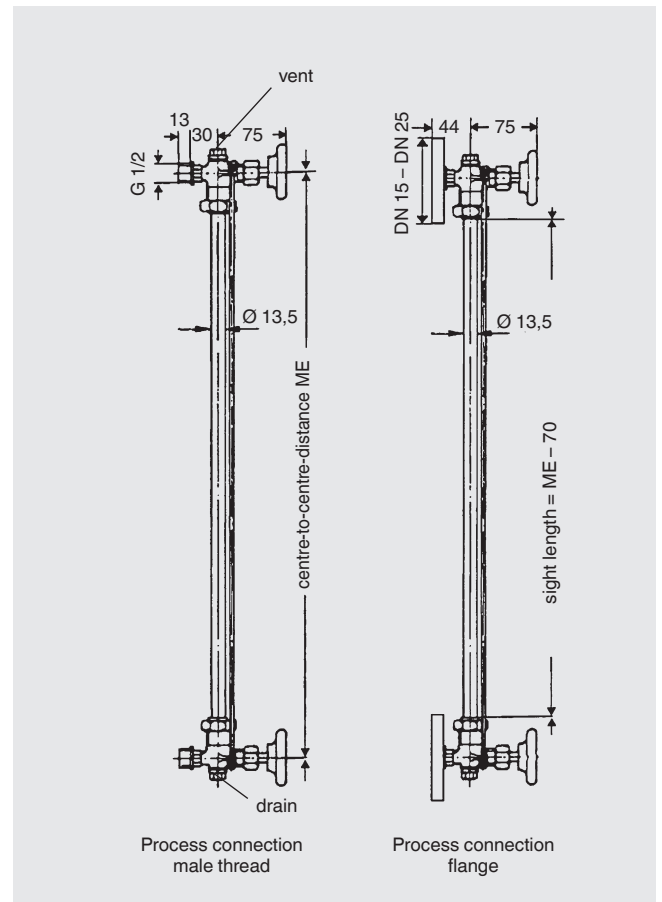

\*) length glasstube = ME – 65 mm

\*\*) length = ME – 55, product temperature max. 80°C.

Length of brass-protection rods ME + 30 mm