

Hydraulic Clamp Nut

Piston system



Series 010 / 110

Features of series

**Axial operating
with Allen key**

Medium remains into the system



The actuator screws has to be turned into the body by using the enclosed Allen key.
The internal medium will flow into the circular groove and raise the ring piston.
With less manual force you create a big hydraulic clamping force.
For to relieve the clamp nut put the actuator screws to the start position
and move the nut to the opposite direction.
The medium remains into the system.

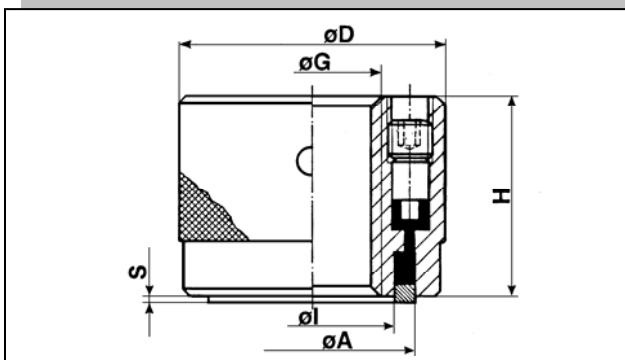

Clamping range 4 mm

Thread	Ring piston		Outer Diameter	Height	Clamping force (achieved by hand)	Part No Clamping range S 4 mm
$\sigma G_{max.}$	σA	σD	σD	H	in kN	
20	34	26	54	60	40	110.04.020
24	40	32	60	67	40	110.04.024
30	52	40	72	75	80	110.04.030
36	55	44	78	77	80	110.04.036
52	72	60	98	80	90	110.04.052
68	92	82	120	80	90	110.04.068
80	100	88	130	85	80	110.04.080
100	125	110	155	95	100	110.04.100

Against corrosion our hydraulic clamp nuts are protected with a brown finish.
The standard sealing systems are suitable for temperatures up to 80°.
The ring piston is locked against drop out.

Special design of hydraulic clamp nuts on request



AVEMAR CZECH s.r.o. | speciální armatury pro měření a regulaci
Branch office | Lihovarská 1199/10 | 716 03 Ostrava - Radvanice | Česká republika
Tel.: +420 596 232 996 (7) | Fax: +420 596 232 998 | www.avemar.cz | avemar@avemar.cz